

## 12' Majestic Mountain Pine Commercial Tree

SKU: T-12-5MM

### Features

- Commercial Grade
- Grow the tree year after year by adding more frames
- 5mm Wide Angle Conical LED Warm White
- 2' high strength steel concentric stacking frames.
- Innovative nesting design for compact storage when not in use
- Tree can be assembled with basic hand tools, no previous experience required.
- Lifetime technical and assembly phone support
- Natural lifelike appearance
- Crush resistant, UV-protected high-strength needles

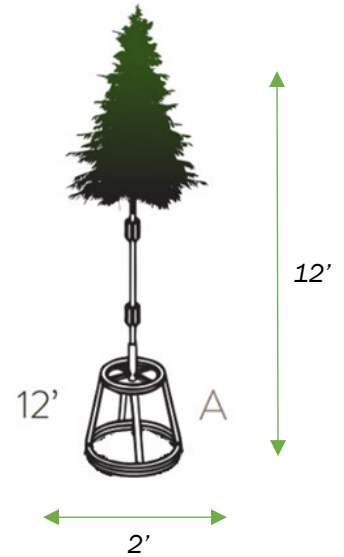

### Material Specs

<b>Lighting:</b>	5mm Wide Angle Conical
<b>Number of LEDs:</b>	2150
<b>Available Colors:</b>	Warm White, Pure White and Multi
<b>LED Effect:</b>	Steady
<b>Electrical Draw:</b>	1.79 Amps
<b>Height:</b>	12'
<b>Diameter:</b>	2' (without foliage) or 8' (with foliage)
<b>Total Tree Tips:</b>	6034
<b>Number of Branches:</b>	
3' Regular Branch	11
6' Top Branch	6
5' Topper:	1
<b>Weights:</b>	
3' Regular Branch	10.7 lbs
6' Top Branch	9.16 lbs
5' Topper:	40lbs
<b>Branch Box Size:</b>	45" X 22" X 18"
<b>Frame:</b>	A Frame, 5' Pole and 5' Topper
<b>Branches on Frame Ring:</b>	6
<b>Construction Type:</b>	Powder-coated frame designed for demanding outdoor applications
<b>Steel Rings:</b>	1" x .065 sq steel tubing ASTM A513
<b>Electrical Harness:</b>	14-gauge double strand wire with thermo jacketed 3 prong plugs
<b>Number of Harness Outlets:</b>	20
<b>Shipping Weight:</b>	270 lbs
<b>Shipping:</b>	2 Pallets (48" X 48")
<b>Recommended Topper Size:</b>	3' Topper

## Electrical Diagram

- One 40 ft. extension cord to the outlet for trees from 12 ft. to 28 ft.
- Extension cords should be dropped to the ground inside of the tree

**\*Please note: The tree top section should plug into two separate female plugs. Do not plug in all 9 strands to one outlet.**

